

CABLE MANAGEMENT



Description

The horizontal metal cable management panel mounts to a standard 19" rack to help you organize horizontal cabling, through a covered cable duct. The 1U cable organizer features a removable top cover that makes it easy to add or remove bundled cables quickly. The duct also offers a series of fingers on either side, as well as pass-through holes at the back to help you route your cables where you need them, and reduce cable strain in the process.

Features

- Material: SPCC
- Colour RAL 9005 (Black)
- Dimension: 482x72x44mm
- Weight: 600gr
- U Height: 1U
- Removable top cover
- Rear panel have pass-through holes

Applications

Installation position: Fixed on the mounting rail. Use with server racks and cabinets to keep cables neat and tidy.

RACK

CABLING

CABLE MANAGEMENT

Technical Drawing

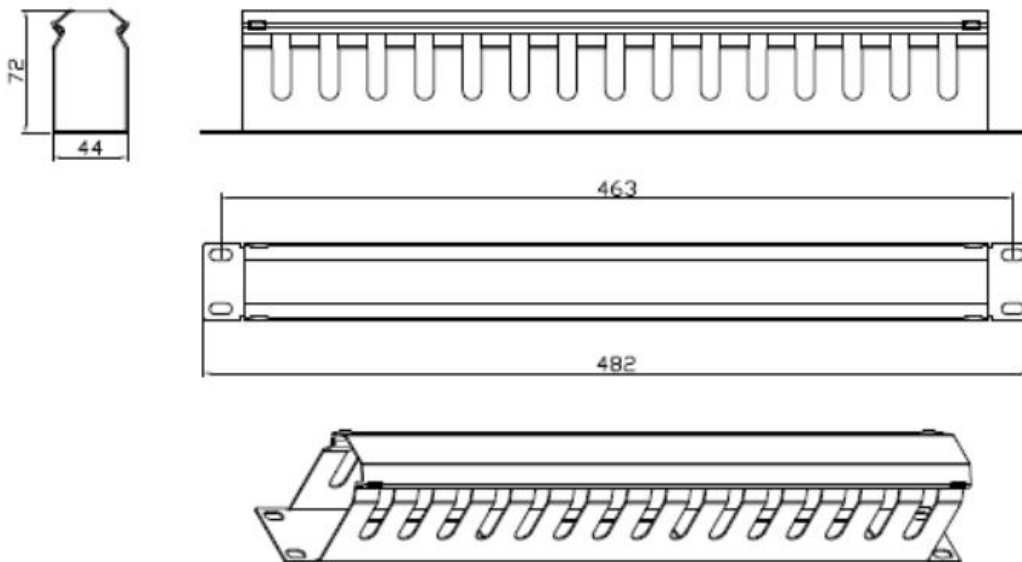

Product Number Information

Code: ACM-301-B

EAN n.	8032958189683
Packaging Unit Single size (mm)	500x83x53
Packaging Unit Single weight (gr.)	600
Carton size (mm)	515x570x435
Carton weight (Kg)	32
Quantity per Carton (un)	50 pcs

